

**ALLWOOD  
SPECIFICATIONS**

**ALLWOOD CABINET SPECIFICATIONS**

- FRONT FRAME:** 3/4" Thick kiln dried solid hardwood. Mortise and tenon or bore and dowel construction frame joinery reinforced with glue and nail. Stiles 1 1/2" wide. Mulls 3" wide. Rails 1 3/4" wide. Stiles and top and bottom rails dadoed to receive ends, tops and bottoms.
- END PANELS:**  
**Standard:** Nominal 1/2" thick (12mm) multi-ply birch veneer plywood dadoed to receive tops and bottoms. End panels are inserted into dado in face frame and recessed 3/16".  
**Upgrade Option:** Nominal 1/2" thick (12mm) multi-ply hardwood plywood with oak, maple or cherry veneer on exterior surface and birch veneer on interior surface. All end panels are constructed with the same dado joinery as above and are recessed 3/16".
- TOP/BOTTOM PANELS:** Nominal 1/2" thick (12mm) multi-ply hardwood plywood. Tops and bottoms set into grooved end panels, front rails and hang rails, glued and stapled. Bottoms are supported at rear of base cabinets by nominal 1/2" thick multi-ply hardwood plywood.
- HANGING RAILS:** Wall cabinets have nominal 3/4" thick (18mm) x 3" high multi-ply hardwood plywood, running full cabinet length at the top and bottom. Base cabinets have a nominal 1/2" thick (12mm) x 3" high multi-ply hardwood plywood hang rail at the top.
- BACK PANEL:** Nominal 1/8" thick (3mm), hardwood plywood. Securely glued and stapled to ends and hang rails.
- SHELVES:** Nominal 5/8" thick (15mm) multi-ply hardwood plywood, 10 7/8" deep with hardwood veneer banded front edge. Shelves are adjustable in all standard wall and base cabinets.
- TOE KICK:** Nominal 1/2" thick (12mm) multi-ply hardwood plywood.
- BASE CORNER BRACES:** High impact, injection molded plastic.
- DRAWERS:** (Standard) Nominal 1/2" thick (12 mm) solid wood front, back and sides. Drawer bottoms are multi-ply hardwood plywood inserted into dado in front, back and sides. All drawer parts glued and stapled together.
- DRAWER GUIDES:** High quality epoxy coated steel, Cushion-Tec, side mounted guides, self adjusting in mounting brackets. Built-in stop, self-closing and stay-closed features with a 100 lb. rated load capacity.
- DOVETAIL DRAWER:** (Upgrade only) Front, back and sides are nominal 3/4" thick (19 mm) solid beech hardwood with dovetail construction. Drawer bottoms are nominal 3/16" (5 mm) multi-ply hardwood birch plywood inserted into dado in front, back and sides. Drawer bottoms are glued and stapled to sides.
- UNDERMOUNT DRAWER GUIDE:** (Standard with dovetail drawer only) High quality steel, undermount construction provides full drawer access. Self adjusting in mounting brackets. Built-in stop, self-closing and stay closed features with a 75 lb. rated load capacity.
- SOFT-CLOSE UNDERMOUNT DRAWER GUIDE:** (Deluxe upgrade with dovetail drawer only) High quality steel, undermount construction provides soft-close feature that helps reduce drawer slamming. Drawers are full extension, self adjusting in mounting brackets. Built-in stop, self-closing and stay closed features with a 100 lb. rated load capacity.
- HINGES:**  
**Standard:** Heavy duty, high quality steel, concealed 6-way adjustable hinge with self-closing feature.  
**Optional:** High quality steel wrap-around hinge with self closing feature. (Standard reveal door styles only)
- FINISH:** Furniture quality protective finish system on doors, drawer fronts, front frames and veneer plywood end panels consisting of sanding, stain, catalyzed sealer and catalyzed clear top coats.

**ALLWOOD UPGRADE NOMENCLATURE**

- Wall Cabinet with Oak, Maple or Cherry Plywood End Panels: ..... WOVEP .....(priced per cabinet)  
 Base Cabinet with Oak, Maple or Cherry Plywood End Panels: ..... BOVEP .....(priced per cabinet)  
 Tall Cabinet with Oak, Maple or Cherry Plywood End Panels: ..... TOVEP .....(priced per cabinet)  
 Dovetail Drawers (includes undermount guide): ..... DDU .....(priced per drawer)  
 Large Dovetail Drawers (includes soft-close undermount guide): ..... \*LDDU .....(priced per drawer)  
 Dovetail Drawers (includes soft-close undermount guide): ..... DDSC .....(priced per drawer)  
 Large Dovetail Drawers (includes soft-close undermount guide): ..... \*LDDSC .....(priced per drawer)  
 Glazed Finish Dovetail Drawers (includes soft-close undermount guide): ..... GDDSC .....(priced per drawer)  
 Glazed Finish Large Dovetail Drawers (includes soft-close undermount guide): .... \*GLDDSC .....(priced per drawer)

\*Use for DB30 and DB36 cabinets on the deep drawers only

*Genuine  
ALLWOOD  
Cabinetry™*

# ALLWOOD CABINET SPECIFICATIONS

**HANGING RAILS** - Wall cabinets have nominal 3/4" thick (18mm) x 3" high multi-ply hardwood plywood, running full cabinet length at the top and bottom. Base cabinets have a nominal 1/2" thick (12mm) x 3" high multi-ply hardwood plywood hang rail at the top.

**BACK PANELS** - Nominal 1/8" thick (3mm), hardwood plywood. Securely glued and stapled to ends and hang rails.

**TOP/BOTTOM PANELS** - Nominal 1/2" thick (12 mm), multi-ply hardwood plywood. Tops and bottoms set into grooved end panels, front rails and hang rails, glued and stapled. Bottoms are supported at rear of base cabinets by nominal 1/2" thick multi-ply hardwood plywood.

**SHELVES** - Nominal 5/8" thick (15 mm), multi-ply hardwood plywood, 10 7/8" deep with hardwood veneer banded front edge. Shelves are adjustable in all standard wall and base cabinets.

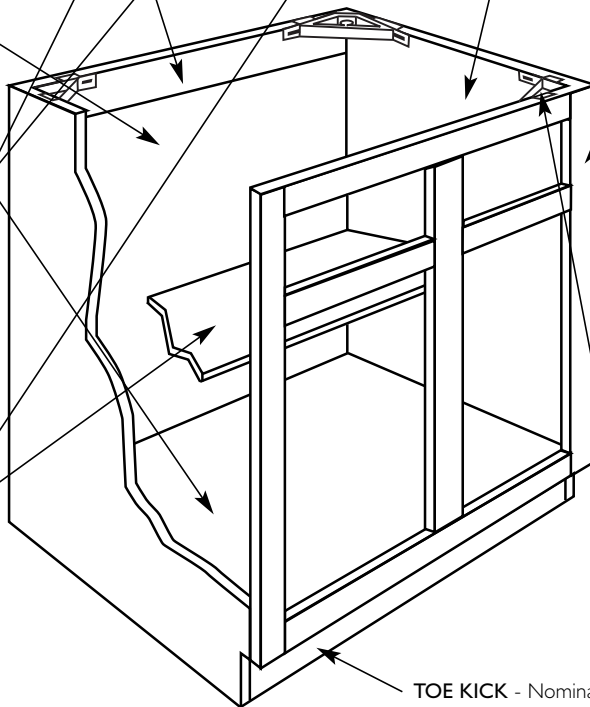
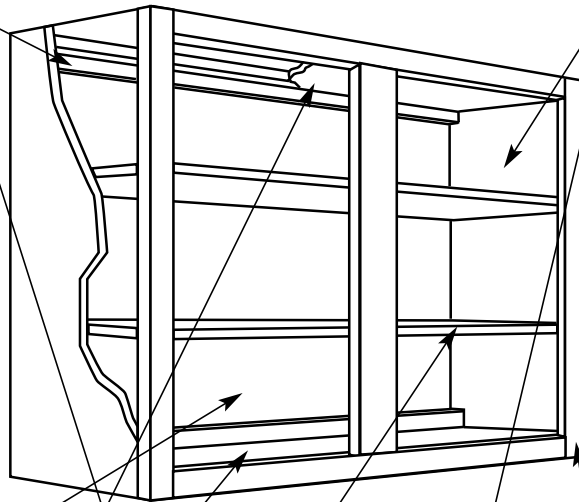

## END PANELS -

**STANDARD:** Nominal 1/2" thick (12mm), multi-ply birch veneer plywood, dadoed to receive tops and bottoms. Ends are inserted into dado in face frame and recessed 3/16".

**UPGRADE OPTION:** Nominal 1/2" thick (12mm), multi-ply hardwood plywood with oak, maple or cherry veneer on exterior surface and birch veneer on interior surface. All end panels are constructed with the same dado joinery as above and are recessed 3/16".

**FRONT FRAME** - 3/4" Thick kiln dried solid hardwood. Mortise and tenon or bore and dowel construction frame joinery reinforced with glue and nail. Stiles 1 1/2" wide. Mulls 3" wide. Rails 1 3/4" wide. Stiles and top and bottom rails dadoed to receive ends, tops and bottoms.

**BASE CORNER BRACES** - High impact, injection molded plastic.

**TOE KICK** - Nominal 1/2" thick (12mm), multi-ply hardwood plywood.

**DRAWERS** - (Standard) Front, back and sides are nominal 1/2" thick (12 mm) solid wood. Drawer bottoms are multi-ply hardwood plywood inserted into dado in front, back and sides. All drawer parts glued and stapled together.

**DRAWER GUIDES** - High quality epoxy coated steel, Cushion-Tec, side mounted guides, self adjusting in mounting brackets. Built-in stop, self-closing and stay-closed features with a 100 lb. rated load capacity.

**HINGES** - (Standard on all doors) Heavy duty, high quality steel, concealed 6-way adjustable hinge with self-closing feature. (Optional) High quality steel wrap-around hinge with self closing feature (available on standard reveal door styles only).

**DOVETAIL DRAWER (Upgrade option)** - Front, back and sides are nominal 3/4" thick (19 mm) solid beech hardwood with dovetail

construction. Drawer bottoms are nominal 3/16" (5 mm) multi-ply hardwood birch plywood inserted into dado in front, back and sides. Drawer bottoms are glued and stapled to sides.

**UNDERMOUNT DRAWER GUIDE (Standard with dovetail drawer only)** - High quality steel, undermount construction provides full drawer access. Self adjusting in mounting brackets. Built-in stop, self-closing and stay closed features with a 75 lb. rated load capacity.

**SOFT-CLOSE UNDERMOUNT DRAWER GUIDE (Deluxe upgrade with dovetail drawer only)** - High quality steel, undermount construction provides soft-close feature that helps reduce drawer slamming. Drawers are full extension, self adjusting in mounting brackets. Built-in stop, self-closing and stay closed features with a 100 lb. rated load capacity.

## ALLWOOD SPECIFICATIONS

Genuine  
**ALLWOOD**  
Cabinetry™